

SPECIFICATION SHEET



Automatic Total Nitrogen & Phosphorus COD Analyzer

NPW-160

This product is used for drainage monitoring in factories and business offices, and auto measurement of total nitrogen, total phosphorus and COD density in water quality control. ultraviolet spectrophotometry method is applied for COD measurement.

Get the coefficient by correlation with hand analysis, and input coefficient to show the value of COD.

Instrument standard: 1 fluid passage, 1 range type, 3 items measurement.



Features

- 120°C 30 minutes pyrolysis is adopted to achieve a sound integration with hand analysis value.
- To test 3 items (TN, TP, COD (UV)) with a multi-wavelength detector.
- Compact design with simple sample and reagent measuring unit.
- Integrative manifold tubing, simple structure
- To reduce measured waste liquid to 15L/month by saving reagent
- The heating resolver adopts an independent simple design
- Pure water in built-in sink can test continuously for about 10 days.
- Tubing in the back has been moved to operate from the front.
- CF Card can store 1 year's data.

Standard Specification

Product name : Automatic Total Nitrogen & Phosphorus COD Analyzer
Model : NPW-160
Measuring objects : Total nitrogen (TN) density and total phosphorus (TP) and COD (UV) density in the water
Measuring method : TN: Alkaline peroxy disulfate decomposition (120°C, 30 minutes) - ultraviolet spectrophotometry
 TP: potassium peroxy disulfate (120°C, 30 minutes) - Molybdenum blue (ascorbic acid) spectrophotometric method.
 COD: 2 wavelength spectrophotometry (ultraviolet 254nm/ visible rays 546nm)

Measurement range:

10mm cell	minimum	maximum
TN	0to5mg/L	0to50mg/L
TP	0to2mg/L	0to20mg/L
COD	0to1Abs	0to2Abs
20mm cell	minimum	maximum
TN	0to2mg/L	0to25mg/L
TP	0to0.5mg/L	0to10mg/L
COD	0to0.5Abs	0to1Abs
5mm cell	minimum	maximum
TN	0to100mg/L	0to200mg/L
TP	0to5mg/L	0to20mg/L
COD	0to1Abs	0to2Abs

Repeatability:

10mm cell		
TN	0 to 50 mg/L	Within ±3%FS
TP	0 to 20 mg/L	Within ±3%FS
COD	0 to 2Abs	Within ±2%FS
20mm cell		
TN	0 to 25 mg/L	Within ±3%FS
TP	0 to 10 mg/L	Within ±3%FS
COD	0 to 2Abs	Within ±2%FS
5mm cell		
TN	0 to 1000 mg/L	Within ±3%FS
	0 to above 100 to 200 mg/L	Within ±5%FS
TP	0 to 20 mg/L	Within ±3%FS
COD	0 to 2Abs	Within ±2%FS

Measurement cycle: measurement / 1 hour (can set to be 1 to 6 hours)

Measurement point: 1 fluid passage

Load capacity : Built-in

calculation

Display mode : Touch screen operation, switch to display year, month and date, moment, measurement value, load capacity, action state etc.

Recording mode : small built-in flash memory (1 years data storage), equipped with a printer with auto winding function.

Calibration method: To use calibration liquid for manual and auto calibration. External signals can be made use for calibration. Zero calibration is conducted automatically when COD is used for measurement.

Analog input signal : Drainage flow rate measurement value input: 4 to 20mA DC
Analog output signal: Measured value / 3 items: 4 to 20mA DC, load resistance less than 600 Ω.
 Load capacity / 3 items: 4 to 20mA DC, load resistance less than 600 Ω.

Contact input signal : external measurement start signal, external calibration start signal, no sample, flowmeter maintenance is underway, contact rating: 24V DC, 0.3A

Contact output signal : measurement value alarm (3 items), load capacity alarm (3 items), major failure, minor failure, maintenance underway, power off, preprocessing startup
 Contact rating: 24V DC, less than 0.3A
 AC100V, less than 0.1A

Ambient temperature and humidity : 2°C to 40°C, less than 85 % (RH)

Specimen water condition : flow: 1 to 3L/min (about 60mL/1 measured)
 Pressure: 20 to 50kPa, temperature: 2 to 40°C

Reagent consumption amount : Peroxide solution: 2.6L
 Sodium hydroxide: 0.37L
 Hydrochloric acid: 0.45L
 Ammonium molybdate: 0.37L
 L- ascorbic acid: 0.37L
 (1 hour/ 1 measurement hour 1 month's consumption amount)

Waste liquid amount : about 15L/month

Power supply : 100VAC±10V, 50/60Hz

Power consumption : 500VA (max), 200VA (average)

Structure : IP52, floor surface setting model

Boundary dimension : 450 (W) × 380 (D) × 1430 (H) mm (excluding water catcher)

Coating color : equivalent to Munsell 5PB8/1

Weight : about 80kg

Measurement flow

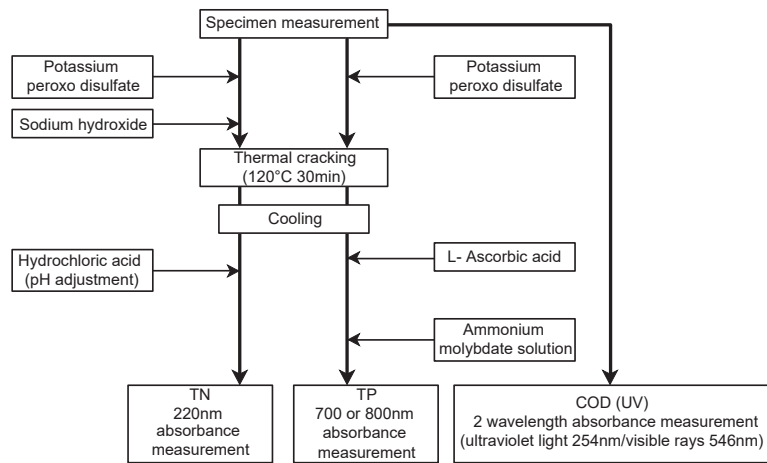

Flow sheet

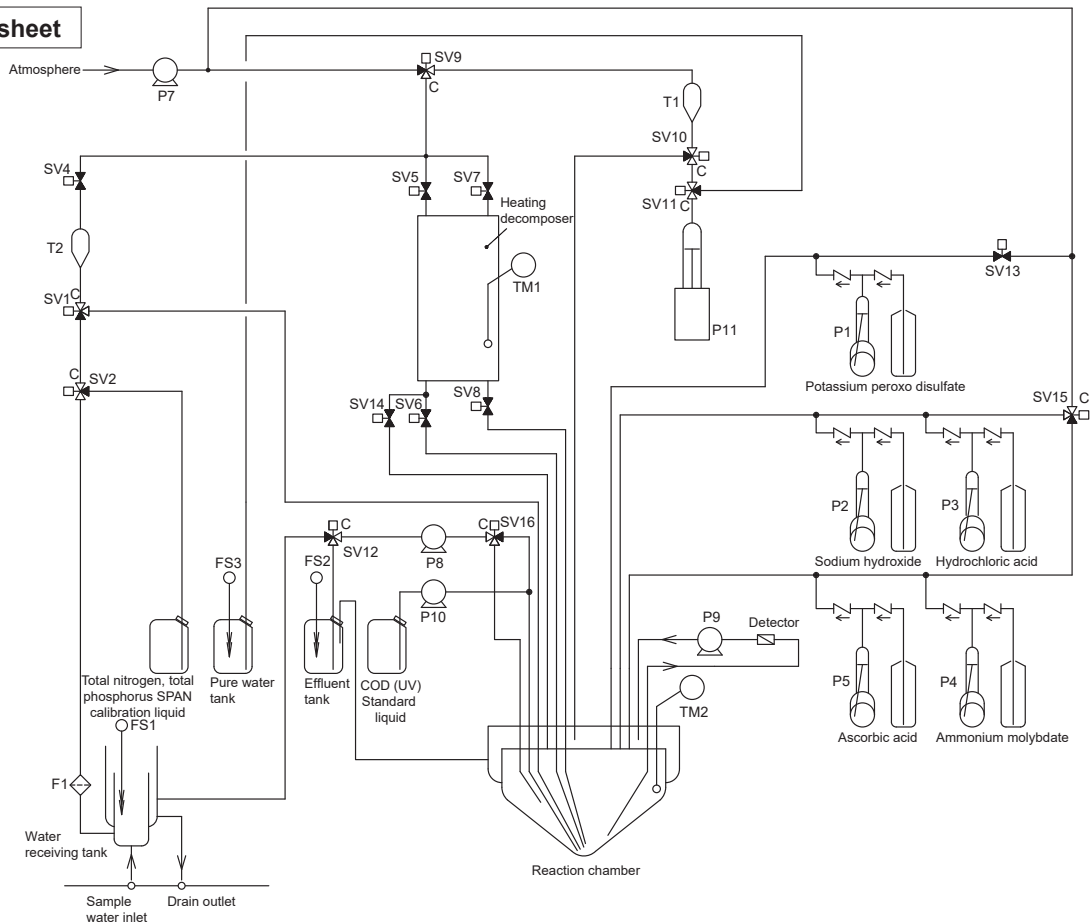

Sample measurement system

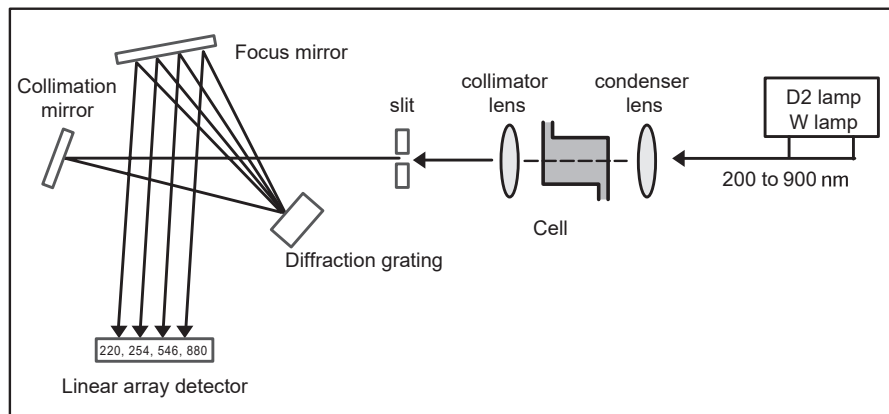
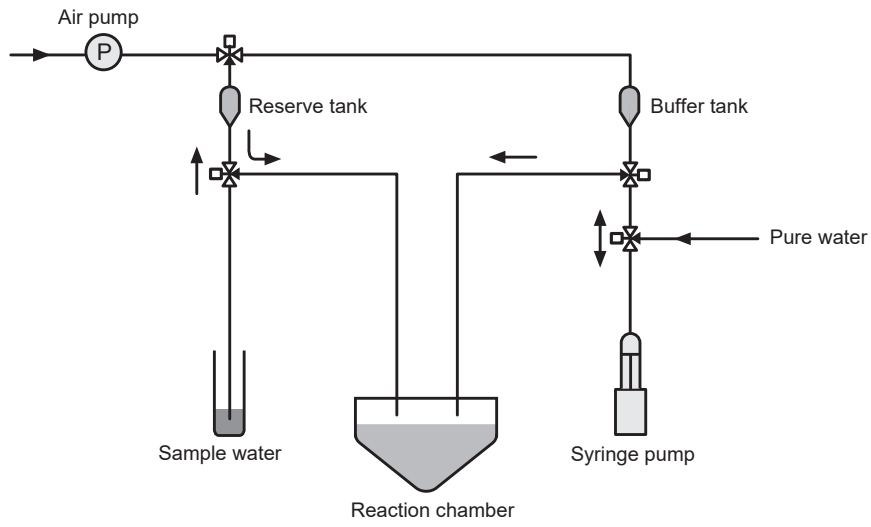

Multi-wavelength detector-based optical system

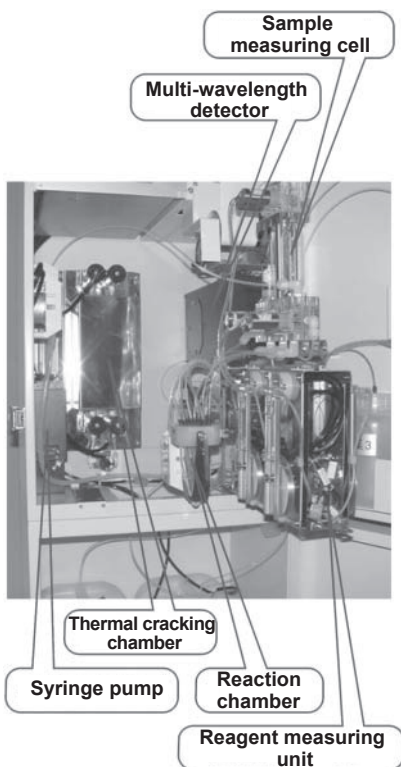

● Printer lettering example

02/03/28	HR	HH:MM	TN	TP	COD	Density (mg/L)	Flow capacity (m ³ /h)	Load capacity (kg/h)
00:00	TN		28.4	2.69	0.07			
	TP		0.136	2.69	0.00			
	COD		32.9	2.69	0.09			
01:00	TN		25.6	2.55	0.07			
	TP		0.133	2.55	0.00			
	COD		30.5	2.55	0.08			
02:00	TN		28.4	2.69	0.07			
	TP		0.136	2.69	0.00			
	COD		32.9	2.69	0.09			
03:00	TN		25.6	2.55	0.07			
	TP		0.133	2.55	0.00			
	COD		30.5	2.55	0.08			
04:00	TN		28.4	2.69	0.07			
	TP		0.136	2.69	0.00			
	COD		32.9	2.69	0.09			
05:00	TN		25.6	2.55	0.07			
	TP		0.133	2.55	0.00			
	COD		30.5	2.55	0.07			
22:00	TN		28.4	2.69	0.07			
	TP		0.136	2.69	0.00			
	COD		32.9	2.69	0.09			
23:00	TN		25.6	2.55	0.07			
	TP		0.133	2.55	0.00			
	COD		30.5	2.55	0.08			
			TN	TP	COD			
			(mg/L)	(mg/L)	(mg/L)			
MAX.			30.2	0.141	35.4	Temperature measurement value		
MIN.			24.6	0.126	28.6	daily newspaper		
AVE.			28.2	0.135	32.3	Maximum value		
			1/24時間	TN load	TP load	Minimum value		
			(m ³ /h)	(kg/h)	(kg/h)	Average value		
MAX.			2.69	0.08	0.00	Load capacity daily newspaper		
MIN.			2.37	0.06	0.00	Maximum value		
AVE.			2.52	0.07	0.00	Minimum value		
			1/24時間	TN load	TP load	Average value		
			(mg/L)	(m ³ /h)	(kg/d)			
Daily average test			TN	28.3	60.5	1.71		
Daily actual flow			TP	0.132	60.5	0.01		
Daily load capacity			COD	32.2	60.5	1.95		

Lettering example with load capacity calculation

● CF card data table example

Date	Time	N measurement value	P measurement value	COD measurement value	Flow	N load capacity	P load capacity	COD load capacity
		mg/L	mg/L	mg/L	m ³ /H	kg	kg	kg
Original data for load capacity calculation								
2003.1.1	0:00	2.026	1.047	1.2	156.4	0.32	0.16	0.18
2003.1.1	1:00	2.026	1.047	1.2	156.4	0.32	0.16	0.18
2003.1.1	2:00	1.898	0.945	1.2	156.39	0.3	0.15	0.19
2003.1.1	3:00	1.898	0.945	1.2	156.49	0.3	0.15	0.19
2003.1.1	4:00	1.914	1.004	1.3	156.45	0.3	0.16	0.2
2003.1.1	5:00	1.914	1.004	1.3	156.5	0.3	0.16	0.2
2003.1.1	6:00	1.833	0.996	1.3	156.44	0.29	0.16	0.2
2003.1.1	7:00	1.833	0.996	1.3	156.5	0.29	0.16	0.2
2003.1.1	8:00	1.982	1.074	1.2	156.46	0.31	0.17	0.2
2003.1.1	9:00	1.982	1.074	1.2	156.4	0.31	0.17	0.2
2003.1.1	10:00	1.851	1.03	1.1	156.45	0.29	0.16	0.18
2003.1.1	11:00	1.851	1.03	1.1	156.46	0.29	0.16	0.18
2003.1.1	12:00	1.808	1.021	1.3	156.46	0.28	0.16	0.2
2003.1.1	13:00	1.808	1.021	1.3	156.45	0.28	0.16	0.2
2003.1.1	14:00	1.654	0.979	1.3	156.44	0.26	0.15	0.2
2003.1.1	15:00	1.654	0.979	1.3	156.46	0.26	0.15	0.2
2003.1.1	16:00	2.068	0.997	1.3	156.45	0.32	0.16	0.2
2003.1.1	17:00	2.068	0.997	1.3	156.46	0.32	0.16	0.2
2003.1.1	18:00	1.793	0.966	1.3	156.43	0.28	0.15	0.2
2003.1.1	19:00	1.793	0.966	1.3	156.51	0.28	0.15	0.2
2003.1.1	20:00	1.952	1.052	1.3	156.41	0.31	0.16	0.2
2003.1.1	21:00	1.952	1.052	1.3	156.52	0.31	0.16	0.2
2003.1.1	22:00	1.92	0.969	1.3	156.44	0.3	0.15	0.2
2003.1.1	23:00	1.92	0.969	1.3	156.51	0.3	0.15	0.2

Note: The original data in CF card is in a format (with a separator)

Terminal connections

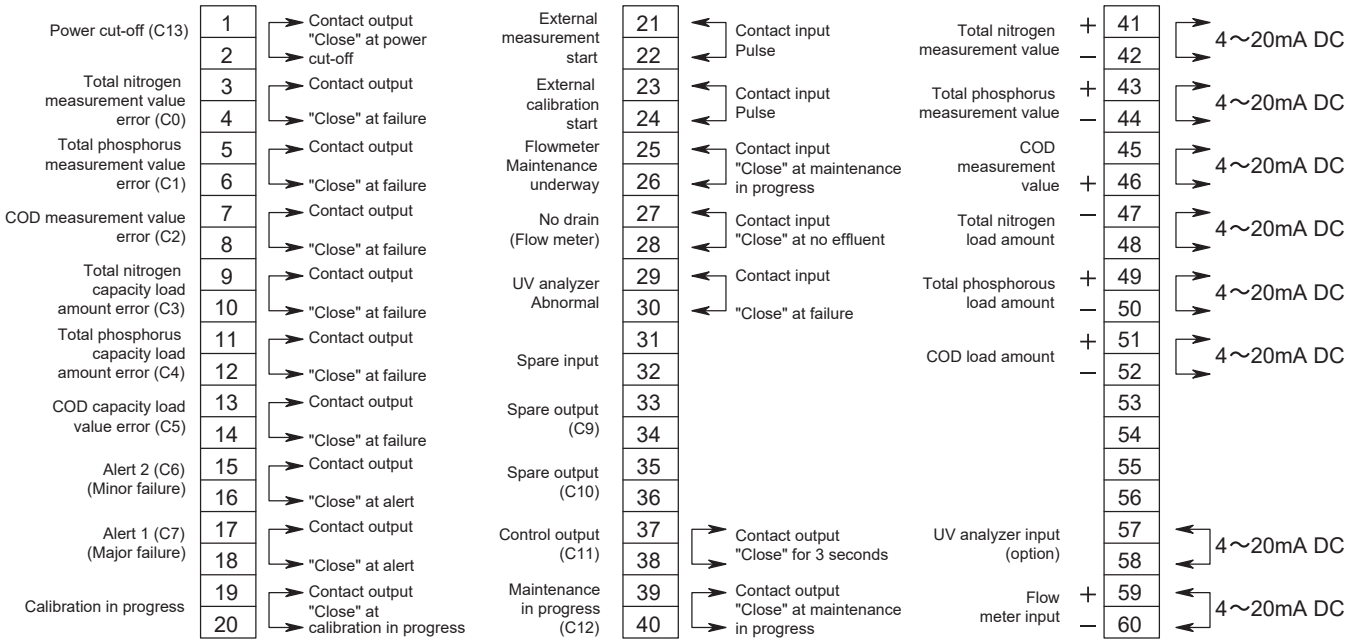

Fundamental performance examples

● 10mm cell linearity

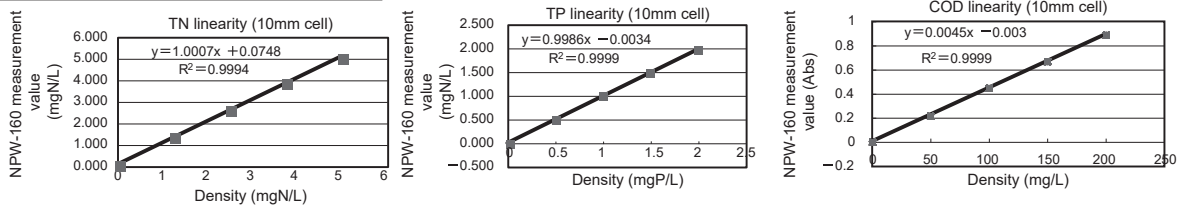

● 10mm cell repeatability

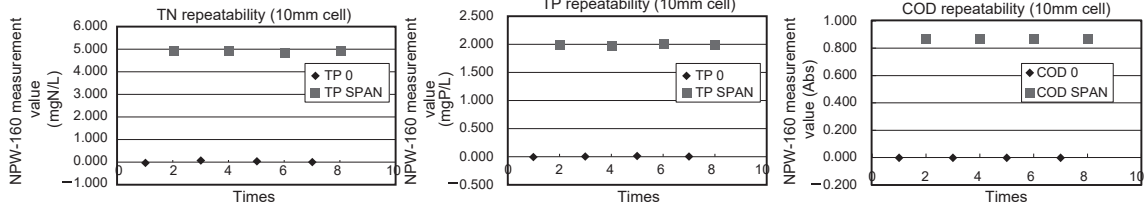

● 20mm cell linearity

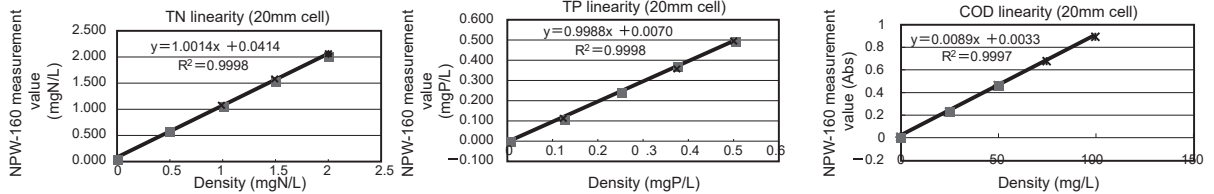

● 20mm cell repeatability

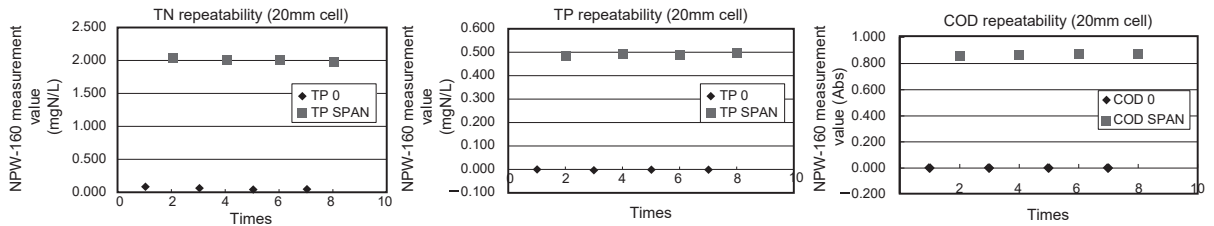

● 5mm cell linearity

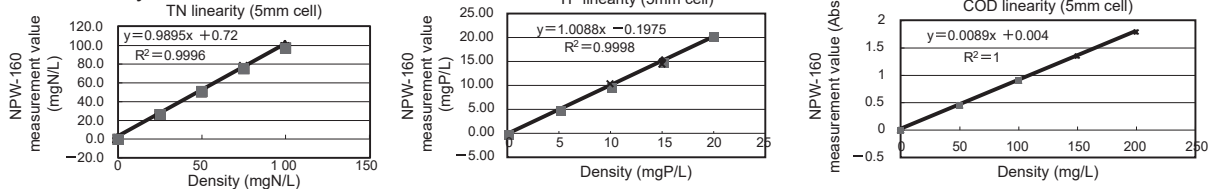

● 5mm cell repeatability

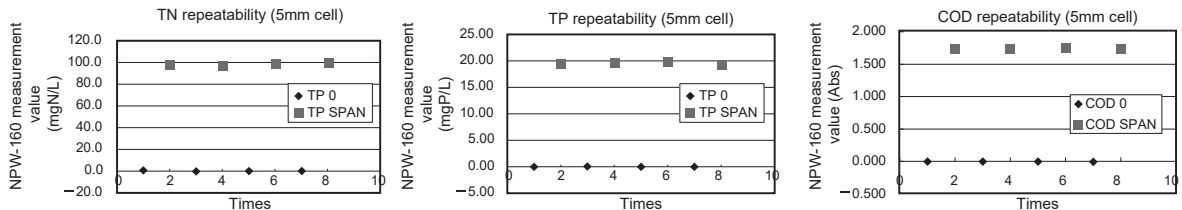

● Comparison between hand analysis value and NPW-160 model indicator value

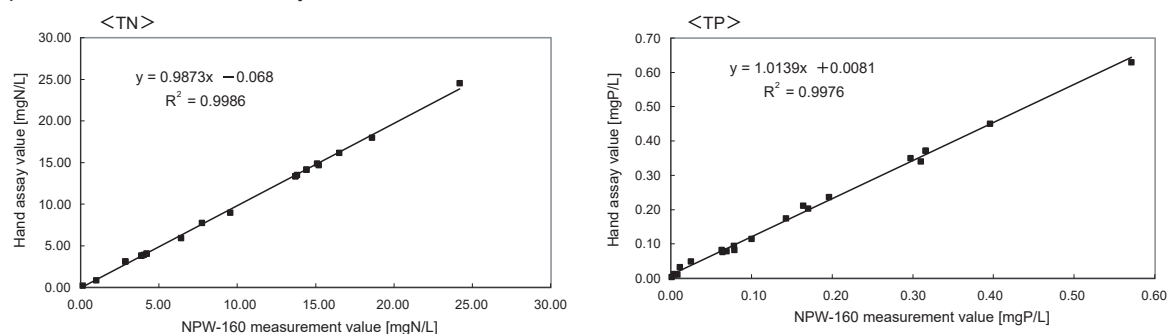

Dimensions

Unit: mm

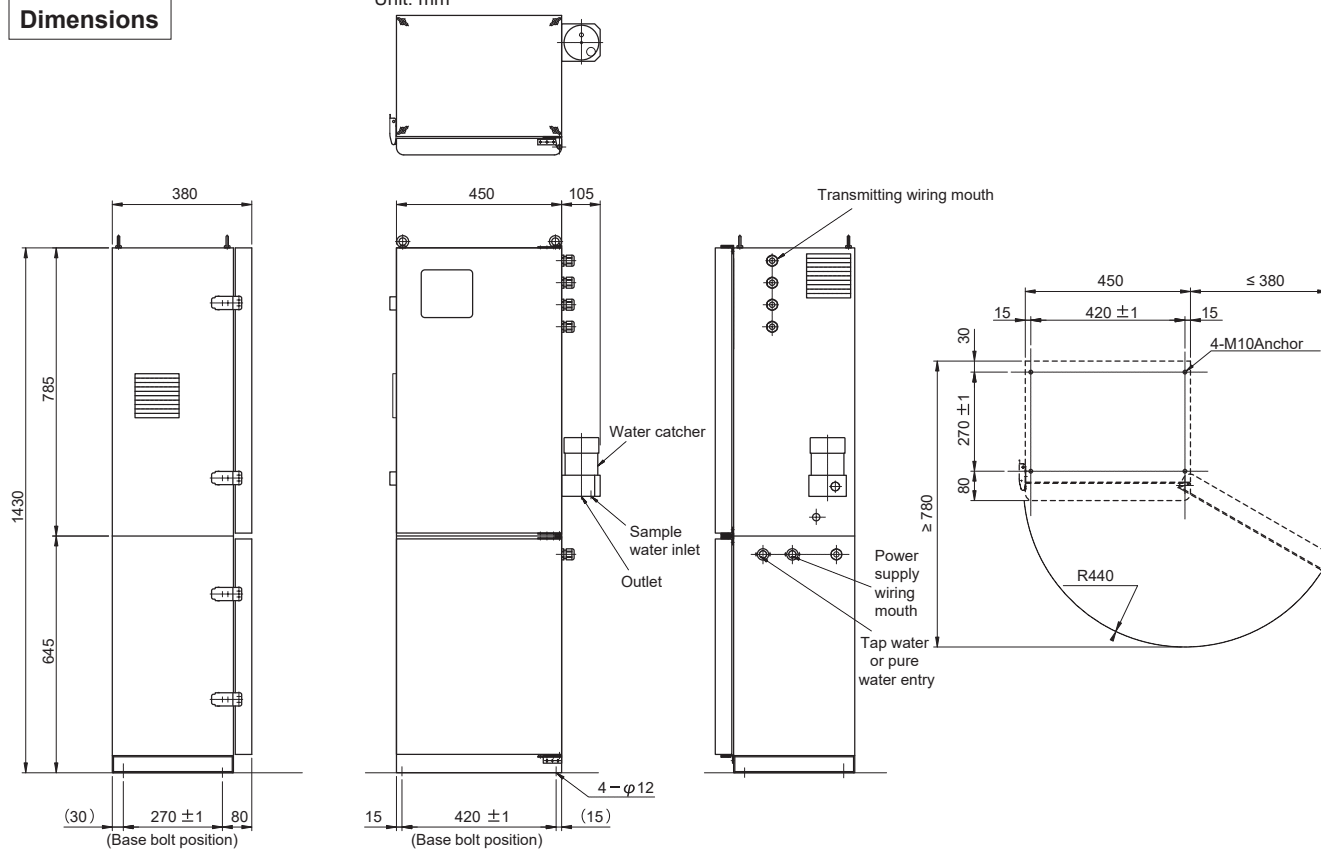

Internal configuration

● Built-in pure water tank (standard)

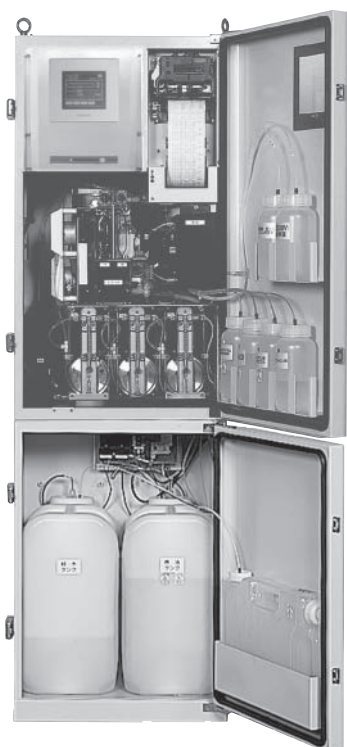

● Built-in deionizer (optional)

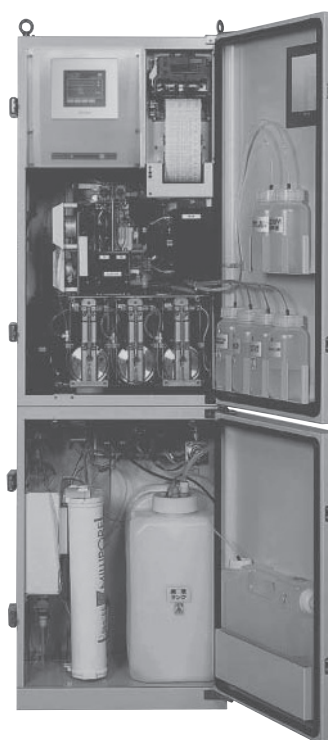

Details in the drawing may be different from actual situation.

Dimensions

Unit: mm

● For external use Cubicle (optional)

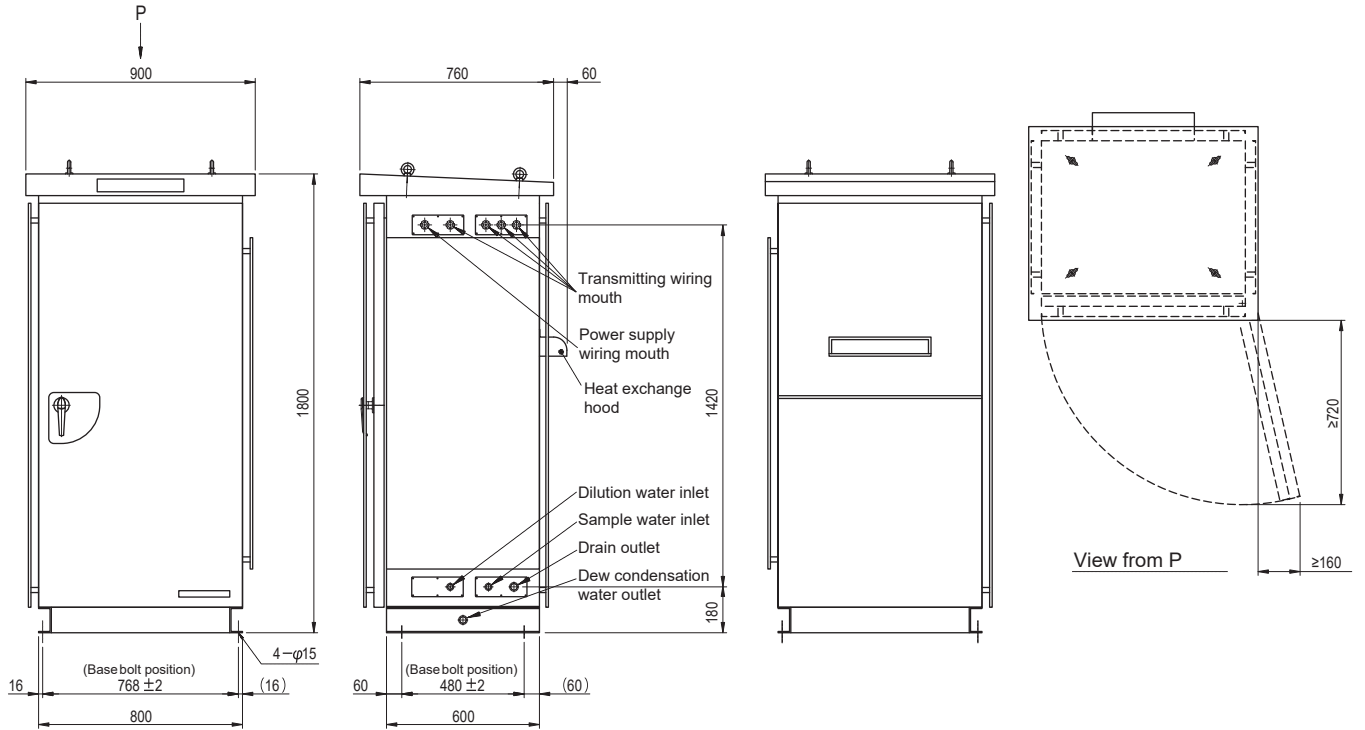

● Adjustment tank (optional)

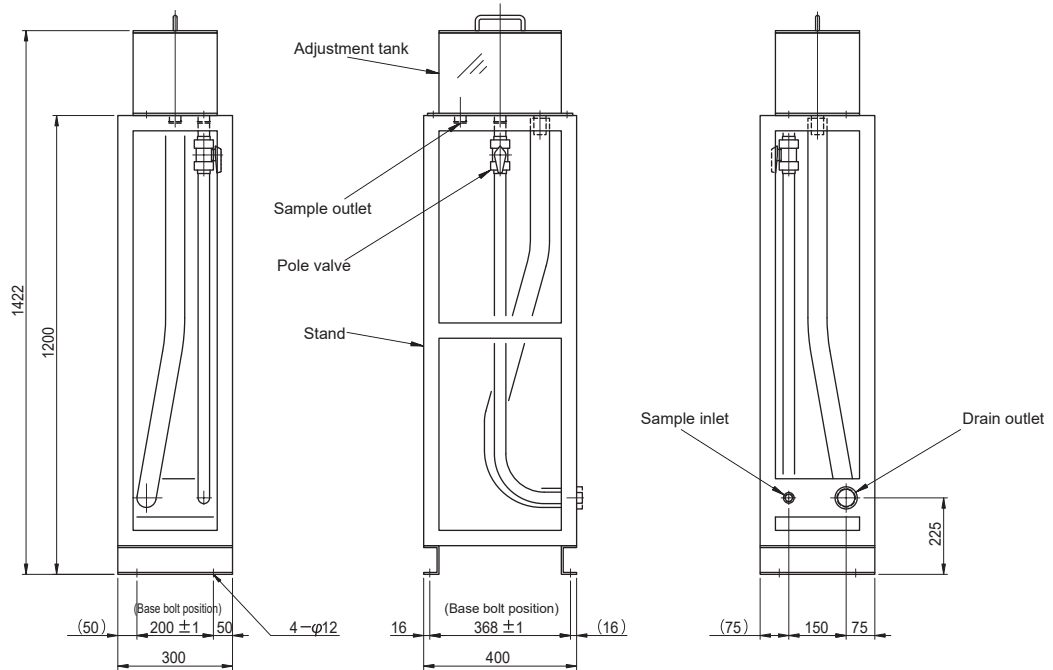

Table of cell Wavelength Measurement Range

<10mm cell> cell Selection of measurement range for 10mm long cell (for low concentration)

Measurement range		Total nitrogen (TN [mg/L])								
		0 to2	0 to5	0 to10	0 to15	0 to20	0 to25	0 to50	0 to100	0 to200
Total phosphorus TP [mg/L]	0 to 0.5							Production is not possible	Production is not possible	Production is not possible
	0 to 1	Correspond with 20mm cell						Production is not possible	Production is not possible	Production is not possible
	0 to 2		○	○	○	○	○	○	Production is not possible	Production is not possible
	0 to 5		○	○	○	○	○	○		
	0 to 10		○	○	○	○	○	○	Correspond with 5mm cell	
	0 to 20	Production is not possible	○	○	○	○	○	○		

<20mm cell> cell Selection of measurement range for 20mm long cell (for low concentration)

Measurement range		Total nitrogen (TN [mg/L])								
		0 to2	0 to5	0 to10	0 to15	0 to20	0 to25	0 to50	0 to100	0 to200
Total phosphorus TP [mg/L]	0 to 0.5	○	○	○	○	○	○	Production is not possible	Production is not possible	Production is not possible
	0 to 1	○	○	○	○	○	○	Production is not possible	Production is not possible	Production is not possible
	0 to 2	○	△	△	△	△	△		Production is not possible	Production is not possible
	0 to 5	○							Correspond with 5mm cell	
	0 to 10	○	Correspond with 10mm cell							
	0 to 20	Production is not possible								

△ : Since the measurement wavelength of the China-oriented product is different, select 20mm for the corresponding low-concentration test sample.

<5mm cell> cell Selection of measurement range for 5mm long cell (for high concentration)

Measurement range		Total nitrogen (TN [mg/L])								
		0 to2	0 to5	0 to10	0 to15	0 to20	0 to25	0 to50	0 to100	0 to200
Total phosphorus TP [mg/L]	0 to 0.5							Production is not possible	Production is not possible	Production is not possible
	0 to 1	Correspond with 20mm cell						Production is not possible	Production is not possible	Production is not possible
	0 to 2								Production is not possible	Production is not possible
	0 to 5								○	○
	0 to 10								○	○
	0 to 20	Production is not possible							○	○

Installation Guidelines

● Built-in deionizer type

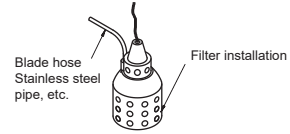
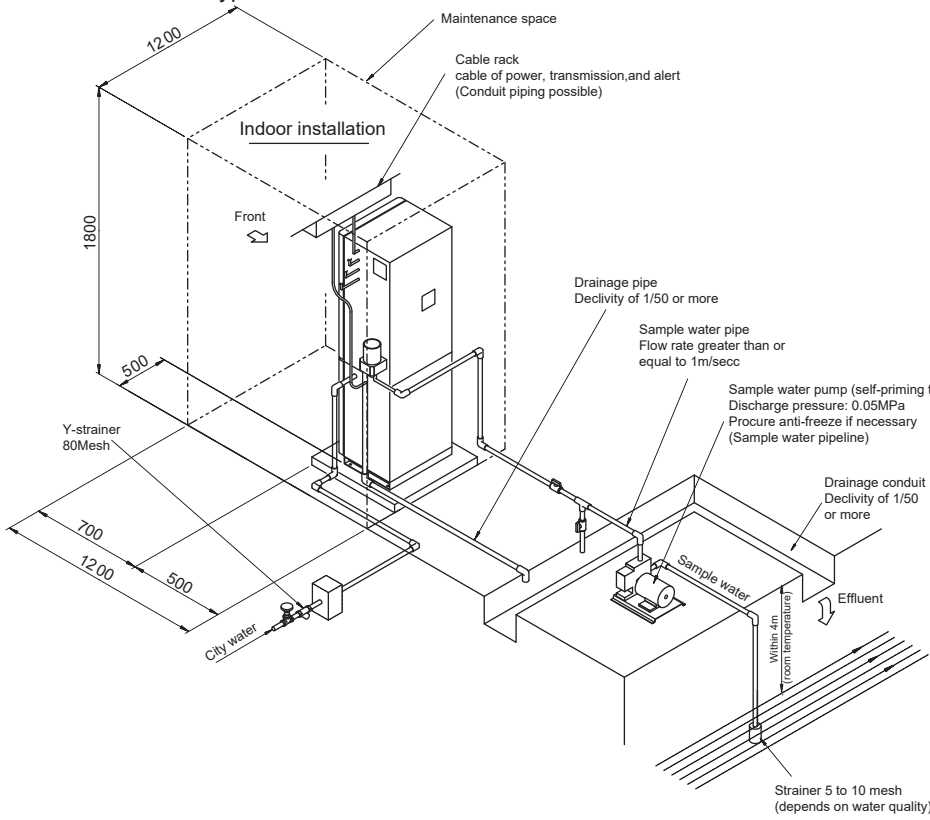

Note Underwater pump

- 1) In consideration of fluctuations in the surface of the water, please ensure that the underwater pump is underwater even at the lowest level.
- 2) To avoid sucking mud or stone, etc., please keep far away from bottom.

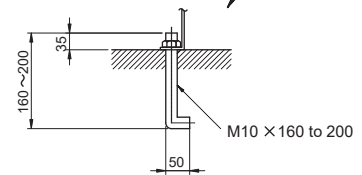
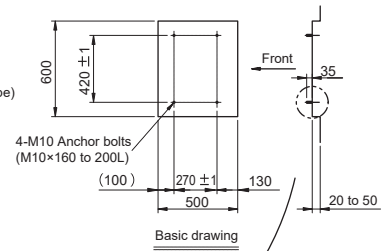

Pipe name	Pipe diameter	Pipe material	Remarks
Sample inlet	Rc 1/2	PTFE tube, blade hose, etc. (external diameter φ6 to 10mm)	
Drain outlet	Rc 3/4	Rigid polyvinyl chloride tube (VP20 or more)	Open to the air (tube end)
City water inlet	Rc 1/2	Rigid polyvinyl chloride tube (VP13 or more)	Option
Pure water inlet	Rc 1/2	Rigid polyvinyl chloride tube (VP13 or more)	Option

Note: Before connecting a pipe to the instrument, fully brush away dust and dirt from the inside of the pipe. If the pipe is dirty, the electromagnetic valve will be clogged.

● With an adjustment tank

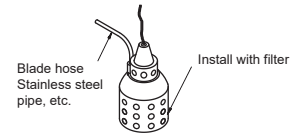
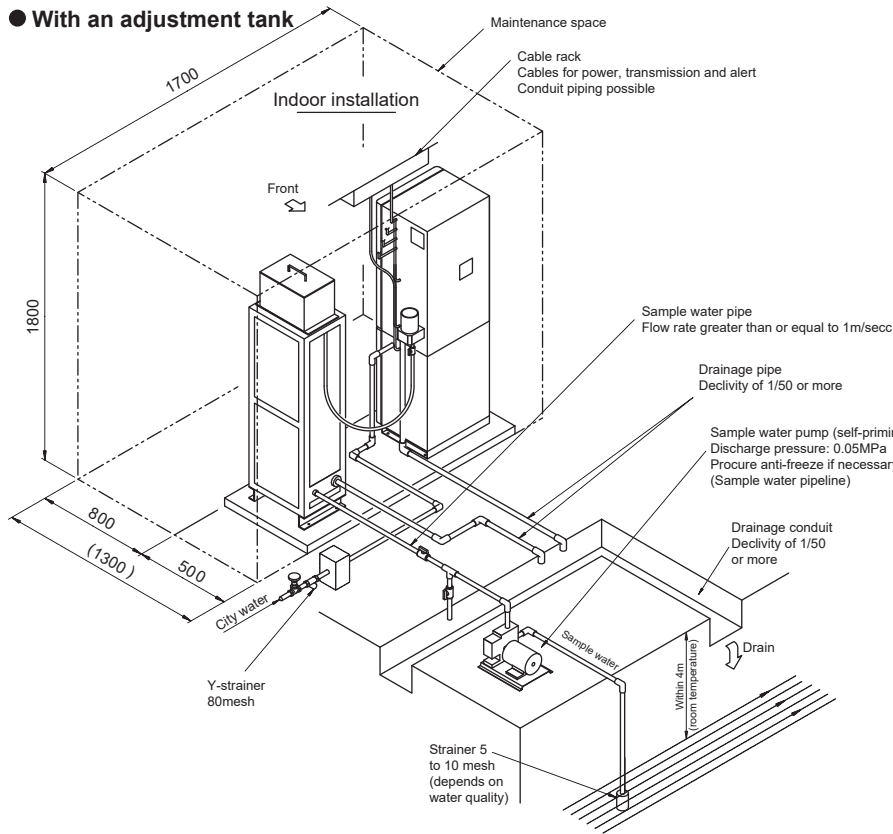

Note Underwater pump

- 1) Considering the changes of water surface, the pump shall remain in water even at the lowest liquid level.
- 2) To avoid sucking mud or stone, etc., please keep far away from bottom.

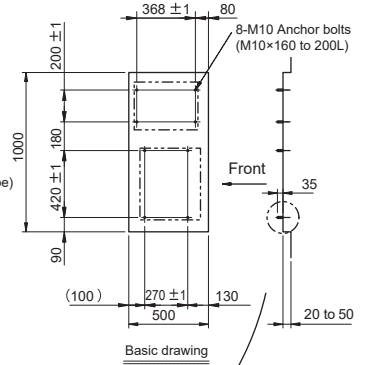

Basic drawing

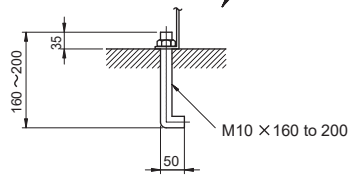

Detailed Plan of Anchor Bolt

Pipe name	Pipe diameter	Pipe material	Remarks
Sample inlet	Rc 1/2	PTFE tube, blade hose etc. (external diameter φ 6 to 10mm) etc.	
Drain outlet	Rc 3/4	Rigid polyvinyl chloride tube (VP20 or more)	Open to the air (tube end)
City water inlet	Rc 1/2	Rigid polyvinyl chloride tube (VP13 or more)	

Note: Before connecting a pipe to the instrument, fully brush away dust and dirt from the inside of the pipe. If the pipe is dirty, the electromagnetic valve will be clogged.

● For external use

Cubicle built-in type

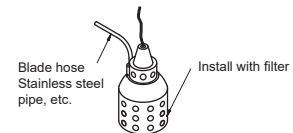
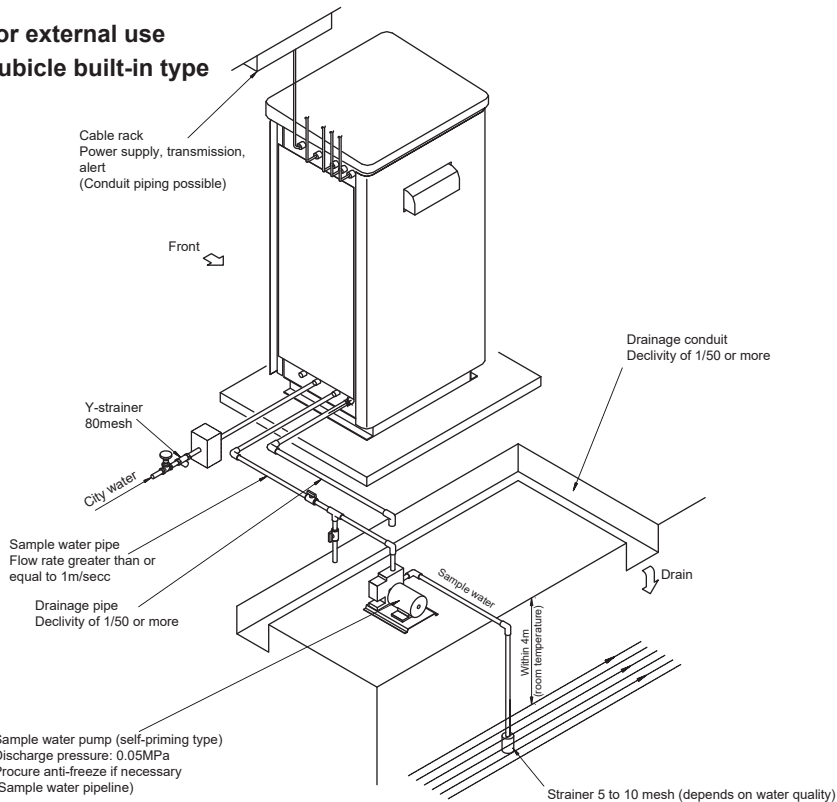

Note Underwater pump

- 1) In consideration of fluctuations in the surface of the water, please ensure that the underwater pump is underwater even at the lowest level.
- 2) To avoid sucking mud or stone, etc., please keep far away from bottom.

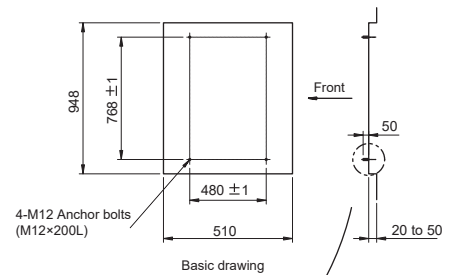

Basic drawing

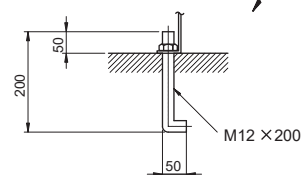

Detailed Plan of Anchor Bolt

Pipe name	Pipe diameter	Pipe material	Remarks
Sample inlet	Rc 1/2	Rigid polyvinyl chloride tube (VP13 or more)	
Drain outlet	Rc 3/4	Rigid polyvinyl chloride tube (VP20 or more)	Open to the air (tube end)
City water inlet	Rc 1/2	Rigid polyvinyl chloride tube (VP13 or more)	

Note: Before connecting a pipe to the instrument, fully brush away dust and dirt from the inside of the pipe. If the pipe is dirty, the electromagnetic valve will be clogged.



DKK-TOA CORPORATION



CAUTION

Please read the operation manual carefully before using products.

Overseas Sales Division:
DKK-TOA Corporation
29-10, 1-Chome, Takadanobaba, Shinjuku-ku,
Tokyo 169-8648 Japan
Tel : +81-3-3202-0225 Fax : +81-3-3202-5685

<http://www.toadkk.co.jp/english>

Information and specifications are subject to change without notice.