



Micro Surgery











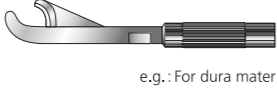
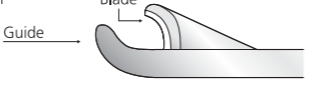

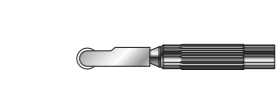

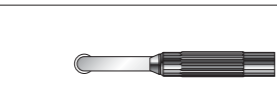

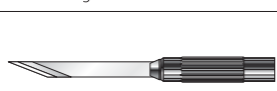
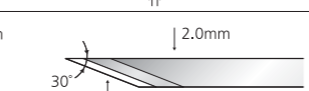
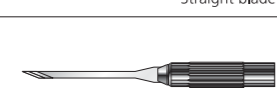

Micro Surgical Blade for Fine Incision

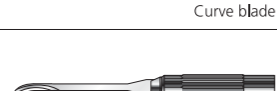
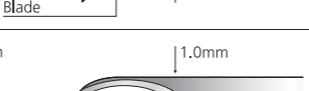
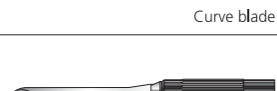
Blade handle

MADE IN JAPAN

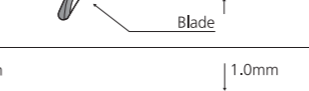
Micro Surgical Blade for Fine Incision

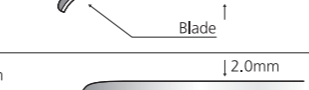
Micro Surgical Blade for Fine Incision is a product developed as a special blade for micro surgery with a systematized blade and handle. A sharp precision tip realized on high-quality stainless steel and a highly original shape guarantee excellent ease of use and working efficiency which can hardly be provided by conventional blades.

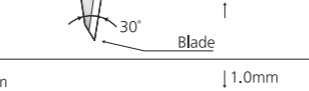
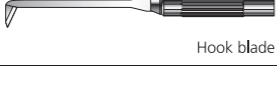
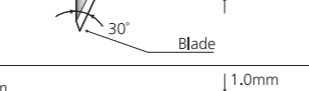
	Actual size	Expanded view
K-5100	 e.g.: For dura mater	Blade thickness : 0.25mm 
K-5110	 e.g.: For dura mater	Blade thickness : 0.25mm 
K-5200	 e.g.: For arachnoid membrane	Depth controller (both side) Blade thickness : 0.25mm ø:2.6mm 
K-5210	 e.g.: For arachnoid membrane	Depth controller (one side) Blade thickness : 0.25mm ø:2.6mm 
K-5300	 Straight blade	Blade thickness : 0.38mm Angle : 30° 
K-5310	 Straight blade	Blade thickness : 0.38mm Angle : 25° 
K-5400	 Curve blade	Blade thickness : 0.38mm 
K-5410	 Curve blade	Blade thickness : 0.38mm 
K-5411	 Curve blade	Blade thickness : 0.38mm 
K-5420	 Curve blade	Blade thickness : 0.38mm Blade tip in round shape 
K-5421	 Curve blade	Blade thickness : 0.38mm Blade tip in round shape 
K-5500	 Hook blade	Blade thickness : 0.38mm 
K-5510	 Hook blade	Blade thickness : 0.38 mm 
K-5520	 Hook blade	Blade thickness : 0.38 mm 











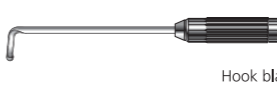
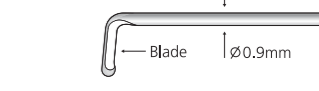

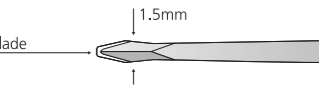
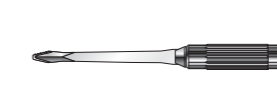
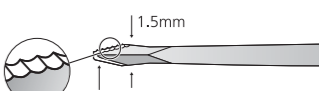
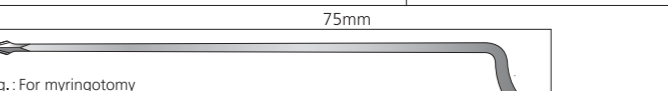

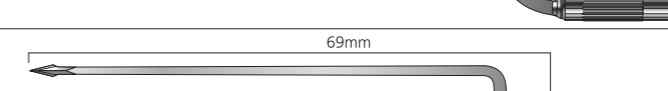

Packed : Box of 5 blades

Sterilized with gamma radiation

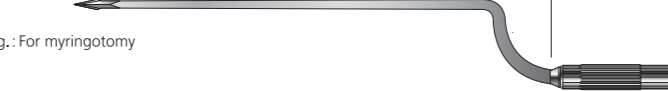
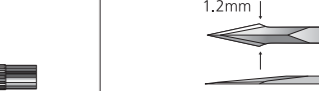
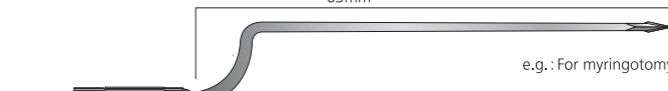
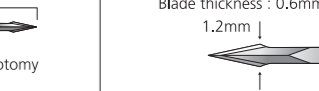
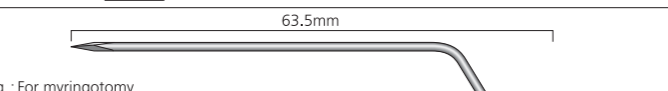
The blade is stored in a plastic case protecting the tip, seal packed and then sterilized with gamma radiation. The blade is therefore available for use immediately after opening of the package.

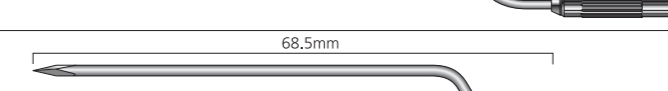
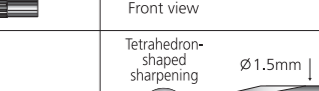
Possibility of sterilization by autoclaving

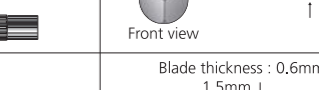
The plastic case is made of an autoclavable resin which makes it possible to sterilize the blade by autoclaving while in the case.

	Actual size	Expanded view
K-6400	 Hook blade	 Blade thickness : 0.9mm
K-5600	 e.g.: For arachnoid membrane	Blade thickness : 0.38 mm 
K-5610	 e.g.: For arachnoid membrane	Blade thickness : 0.38mm Saw-toothed on one face 
K-18R	 e.g.: For myringotomy	75mm  Blade thickness : 0.6mm 1.8mm
K-15R	 e.g.: For myringotomy	69mm  Blade thickness : 0.6mm 1.5mm
K-15L	 e.g.: For myringotomy	69mm  Blade thickness : 0.6mm 1.5mm
K-12R	 e.g.: For myringotomy	63mm  Blade thickness : 0.6mm 1.2mm
K-12L	 e.g.: For myringotomy	63mm  Blade thickness : 0.6mm 1.2mm
K-12T	 e.g.: For myringotomy	63.5mm  Tetrahedron-shaped sharpening Ø 1.2mm Front view
K-15T	 e.g.: For myringotomy	68.5mm  Tetrahedron-shaped sharpening Ø 1.5mm Front view
K-30	 e.g.: For laryngotomy	53.5mm  Blade thickness : 0.6mm 1.5mm
K-50S	 e.g.: For nasal mucosa	29.5mm  Blade thickness : 0.6mm 2.8mm 10mm
K-28B	 e.g.: For nasal mucosa	One side sharpening 90 degree curved  Blade thickness : 0.25mm 2.8mm

Packed : Box of 5 blades

Blade handle

The special blade handle made of a titanium alloy is lightweight and easy to use and has excellent durability.

* The length shown below includes the base of the blade.

Straight type Actual size

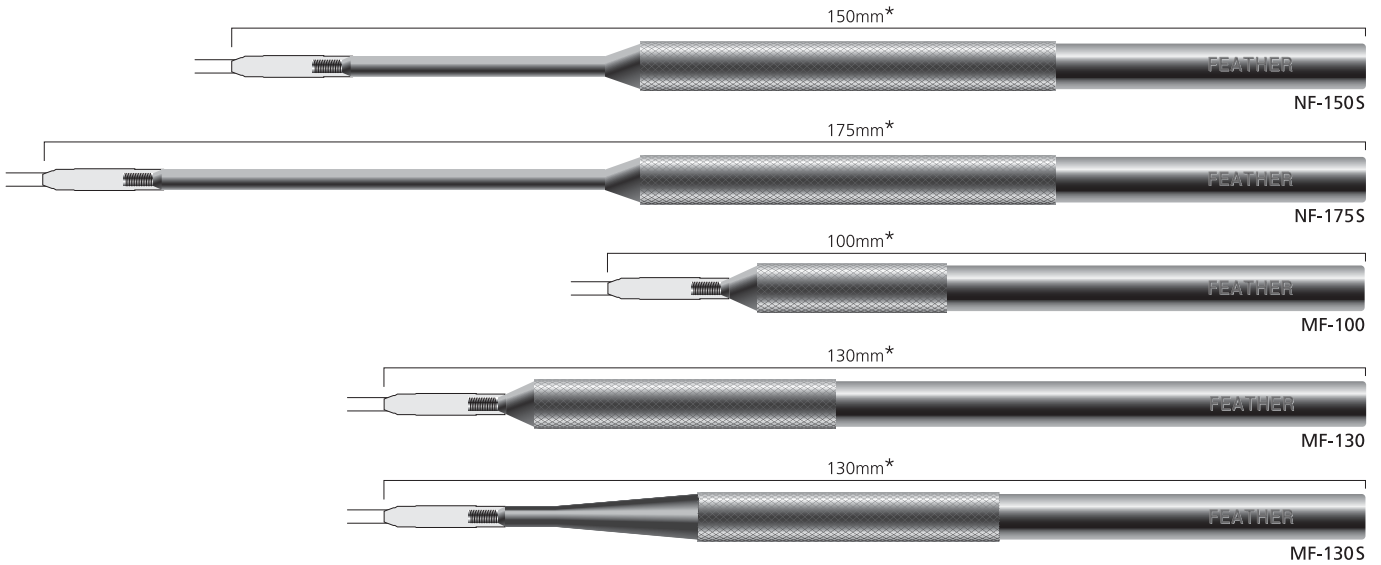

Bayonet type 50% size

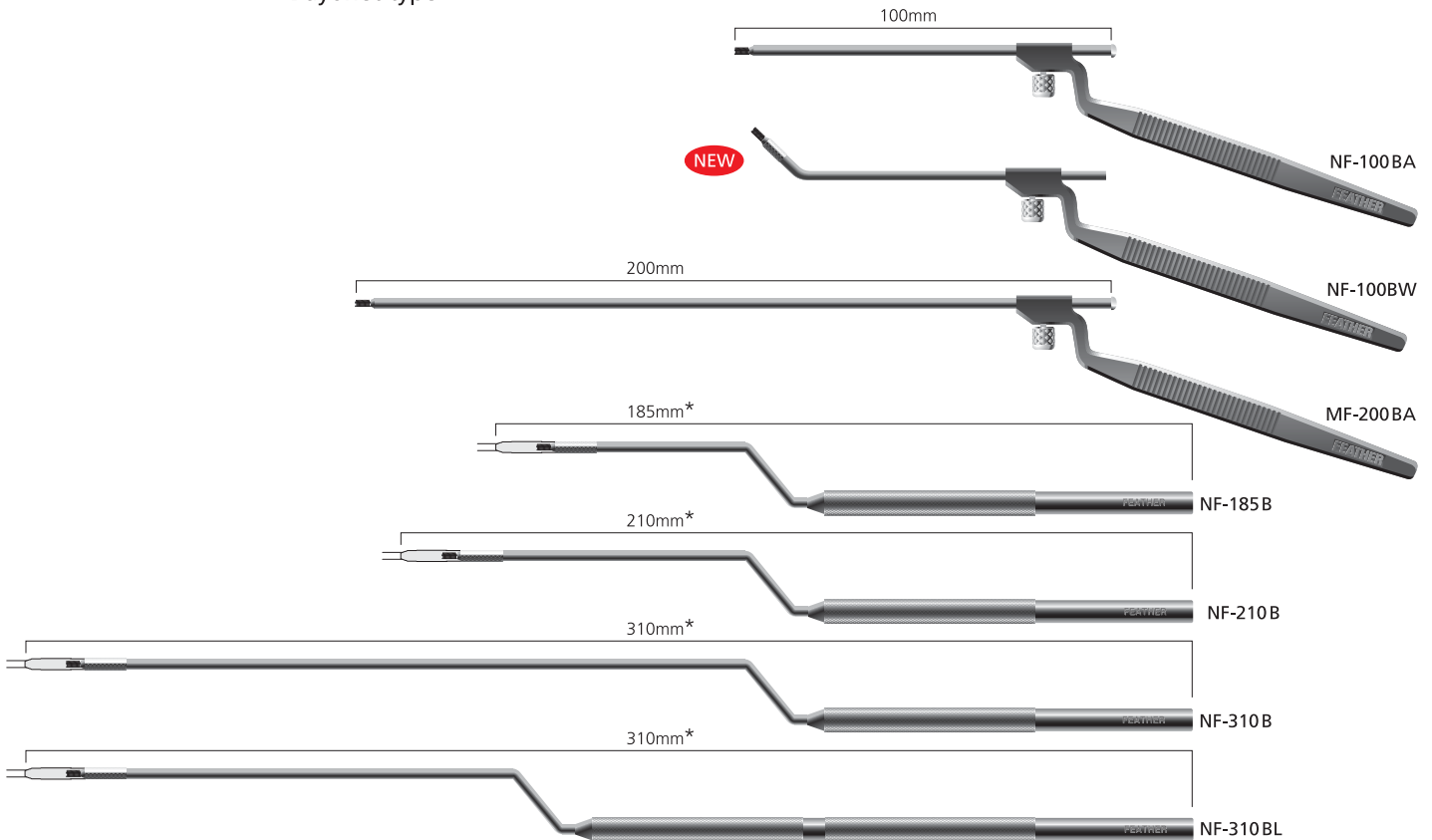

Blade and handle assembly

<p>1 Screw into blade base</p> <p>Squeeze case tightly here.</p>	<p>Firmly hold the blade case in the striated area. Then, while keeping the blade from turning, screw the tip of the handle into the base of the blade.</p>	<p>2</p> <p>Being careful not to damage the blade point, lower the handle grip and remove the blade from the case.</p>
<p>For straight type handles</p>	<p>Once the blade has been removed from the case, tighten the screw until it turns no further.</p>	<p>For bayonet type handles</p> <p>Angle adjusting screw</p> <p>Face the blade in the desired direction. While holding it still with your fingers, tighten the angle adjusting screw until it turns no further.</p>

K-5100 / K-5110

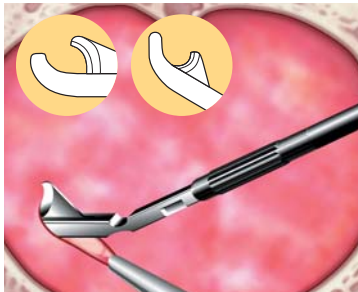

Open a small slit in the dura mater with the blade, insert the guide part of the dura mater blade, and adjust the angle of the blade so that the tip may touch the dura mater at a right angle.



Pinch one end of the dura mater with a pincette, add tension and cut the dura mater while pushing it.
(If the cutting is difficult, readjust the angle of the blade.)

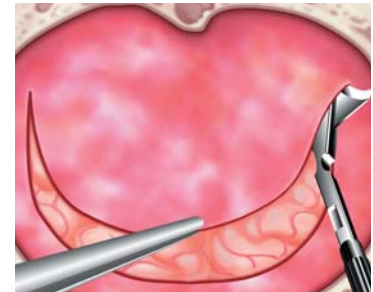

K-5200 / K-5210

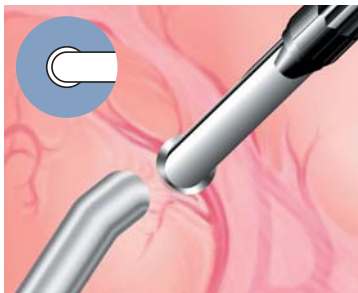

Cut the arachnoid membrane on the tissue and the blood vessel with the circular blade while gently pushing it.
(If the tip of the blade cannot be seen well, use a single-side guard K-5210.)



A safety guard is provided, but the blade may penetrate deeper than necessary if you push too strongly. Start cutting gently and then increase the cutting power gradually.

K-5610

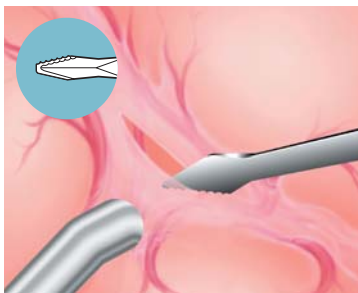

The arachnoid membrane running on the blood vessel can be cut safely by means of a saw-tooth tip.

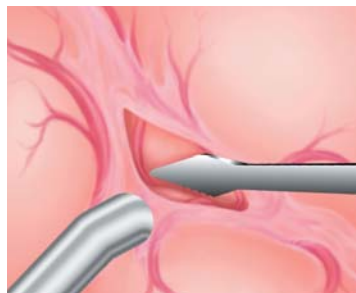

It is also possible to peel off the arachnoid membrane and the brain by using the side face of the blade.



FEATHER SAFETY RAZOR CO., LTD.
OVERSEAS TRADE DIVISION

3-70, OHYODO MINAMI 3-CHOME, KITA-KU, OSAKA 531-0075, JAPAN
PHONE: +81-6-6458-1638 FAX: +81-6-6458-1611
URL www.feather.co.jp/ E-mail overseas@feather.co.jp